

Notes

- The MB-02 has been setup for -ve logic, that is a logic 0 indicates an active signal.
- Mach3 needs to be setup for Active low signals on all outputs and inputs.
- The Stepper Drive enable is a toggle switch that when closed will disable the drives

GeckoDrive G201X Stepper Drives

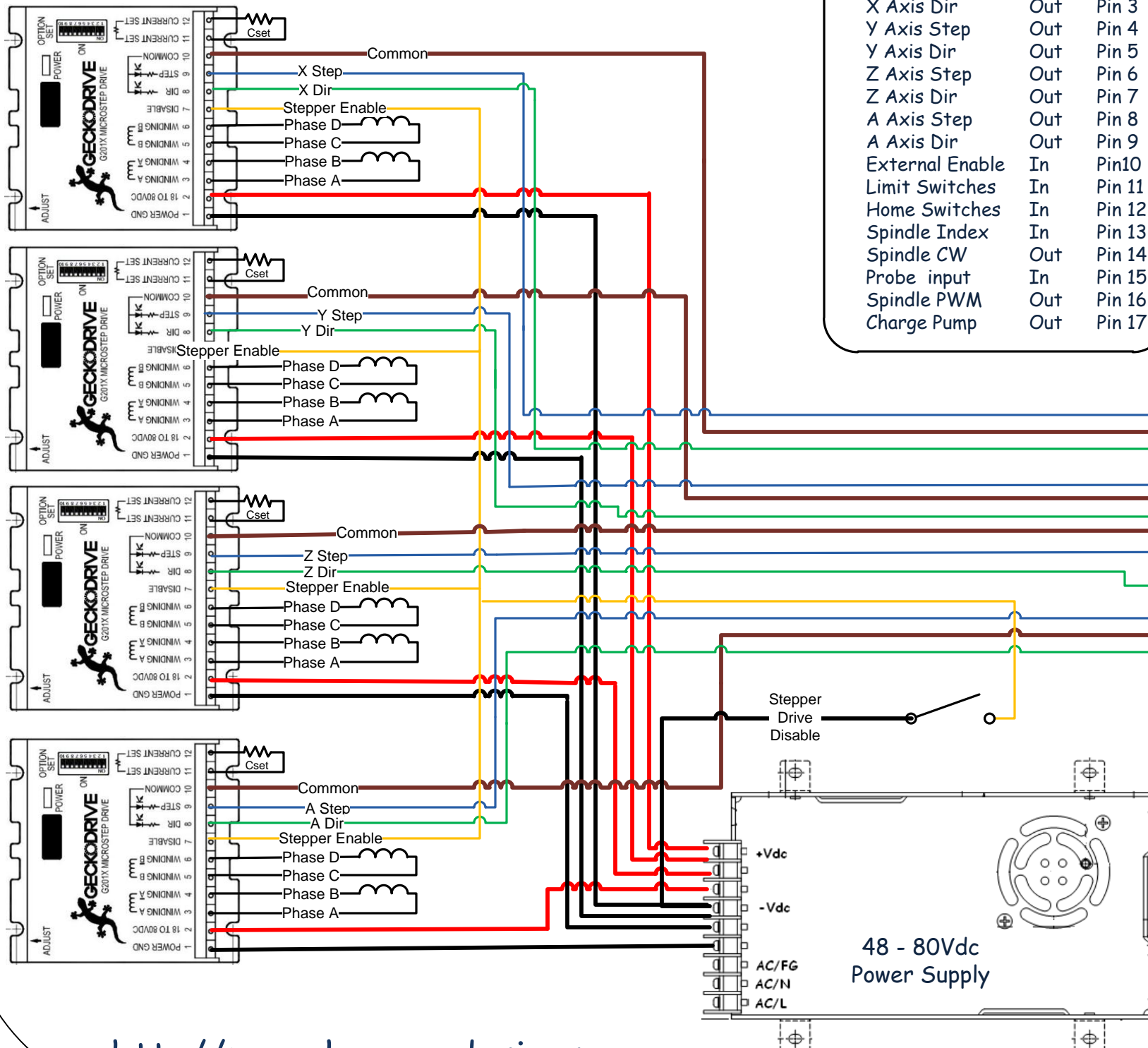

Parallel Port Pin Assignments

Signal	Type	Pin
Spindle CCW	Out	Pin 1
X Axis Step	Out	Pin 2
X Axis Dir	Out	Pin 3
Y Axis Step	Out	Pin 4
Y Axis Dir	Out	Pin 5
Z Axis Step	Out	Pin 6
Z Axis Dir	Out	Pin 7
A Axis Step	Out	Pin 8
A Axis Dir	Out	Pin 9
External Enable	In	Pin 10
Limit Switches	In	Pin 11
Home Switches	In	Pin 12
Spindle Index	In	Pin 13
Spindle CW	Out	Pin 14
Probe input	In	Pin 15
Spindle PWM	Out	Pin 16
Charge Pump	Out	Pin 17

DC-03 V3 DigiSpeed

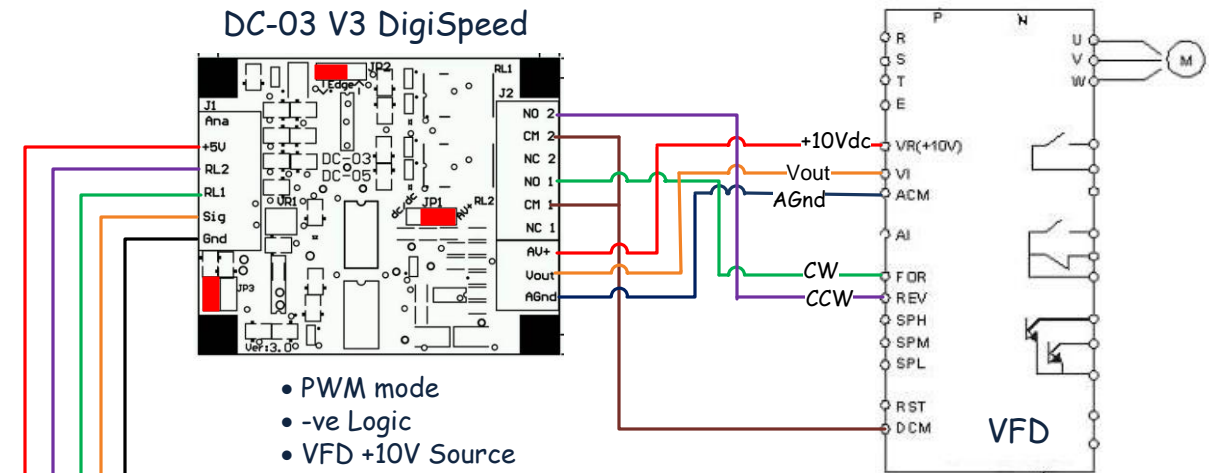

- PWM mode
- -ve Logic
- VFD +10V Source

MB-02V6 Breakout Board

- JP1 - Enable controlled via EN low and Charge Pump
- JP2a - Parallel Port pins D2-D9 are selected as outputs
- JP2b - Enable sourced from EN inputs
- Vcom - Common terminals are set to 5V
- IN - Input Pull-ups are to 5V
- JP4 - Output Pull-ups are to 5V
- JP7 - D2-D9 Pull-ups are to 5V

